

## Barriers MAGSTOP

**MTS 6  
MTS 8**

Technical Data :		Type	MTS 6	MTS 8
Max. barrier width	feet		26'	33'
Opening/closing time	s		6.5	8.5
Voltage V			115	115
Frequency	Hz		60	60
Power consumption	W		280	280
Housing width	inches		18.5"	18.5"
depth	inches		14.5"	14.5"
height	inches		43"	43"
Weight excluding boom	Lbs		298	298
Motor			SAM 210-24	SAM 210-34
Capacitor	C1/C2 µF		30/20	30/20

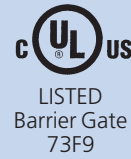

LISTED  
Barrier Gate  
73F9

### Technology

The combination of our patented torque motor and a sinusoidal lever system represents a simple drive system with high reliability. This drive system permits fast opening and closing times without "bouncing" of the boom in the end positions. The sinusoidal lever system ensures that the boom is locked in both end positions. In the event of power failure, however, it can easily be moved by hand.

The boom weight is exactly balanced by means of built-in springs. Adjustment to the appropriate boom length is carried out at the factory before delivery. Modifications such as shortening of the boom or the attachment of sign-boards can be adjusted without difficulty on site during installation.

### Drive

The heart of the Magnetic barrier is the 115 V AC patented blockable torque motor. It requires neither limit switches nor a slip clutch and is maintenance-free.

The torque motor can be blocked in any position without causing damage. In the end positions, it stops with the voltage still applied, and locks the boom via the lever system. With MTS barriers, the motor power is reduced to about 15 W in the end positions to economise on operating costs.

The heat generated by the torque motor prevents condensation and corrosion, ensuring reliable and problem-free operation particularly in winter.

### Housing

A steel frame construction with galvanized, phosphate-treated sheet steel cladding is used for Magnetic barriers MTS 6 and MTS 8. The plastic coating provides optimum protection against corrosion.

The fold-out detachable fixing plate for control equipment consists of colourless anodised aluminium. All components in the barrier housing are easily accessible via the maintenance hatch and the detachable hood.

The housing is coated, as standard, in the colour RAL 2000. Special colours are available if required at extra cost.

### Version

All barriers are available in both "right-hand" or "left-hand" versions.

The hatch to the control equipment is on the road side.

### Barrier Boom

The barrier boom consists of octagonal, 1/10" thick special aluminium section of dimensions 5" x 3 1/2". The maximum barrier width is 33'. The section is coated in white plastic (RAL 9010) and laminated with a red reflective film. Hence the boom is readily visible even at night.

### Control

Magnetic offers a wide range of control equipment. From simple controls with reversing switches to the MUA multi-function control device, or even the fully automatic unit with MCU control device. A detailed description of the various control devices is available on request. All the necessary control devices are mounted on the fold-out fixing plate.

## Safety

The following safety points should be observed with regard to the installation and operation of a Magnetic barrier:

1. The concrete foundation is to be provided in accordance with Works Document Info MM 5115 by the builder.
2. A distance of at least 24" is to be maintained between the boom tip and the nearest building or wall.
3. For permanent installation, a main switch which disconnects all poles is to be provided by the builder.
4. Opening and closing operations must be observed! Installation of the operating elements outside the field of view is not permitted; a visual link must exist between the barrier unit and the control elements.
5. During operation, the presence of persons or goods in the movement zone of the boom is not permitted.
6. When a boom length of 12' is exceeded, the installation of a pendulum support or support post is required.
7. The boom fixing is designed to withstand wind strengths of max. 10 Beaufort Scale (= 10.44 Lb/sqft; 500 N/m<sup>2</sup>).

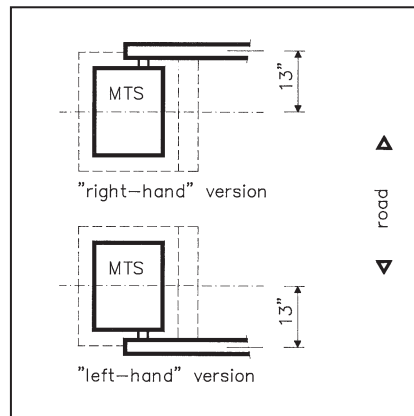
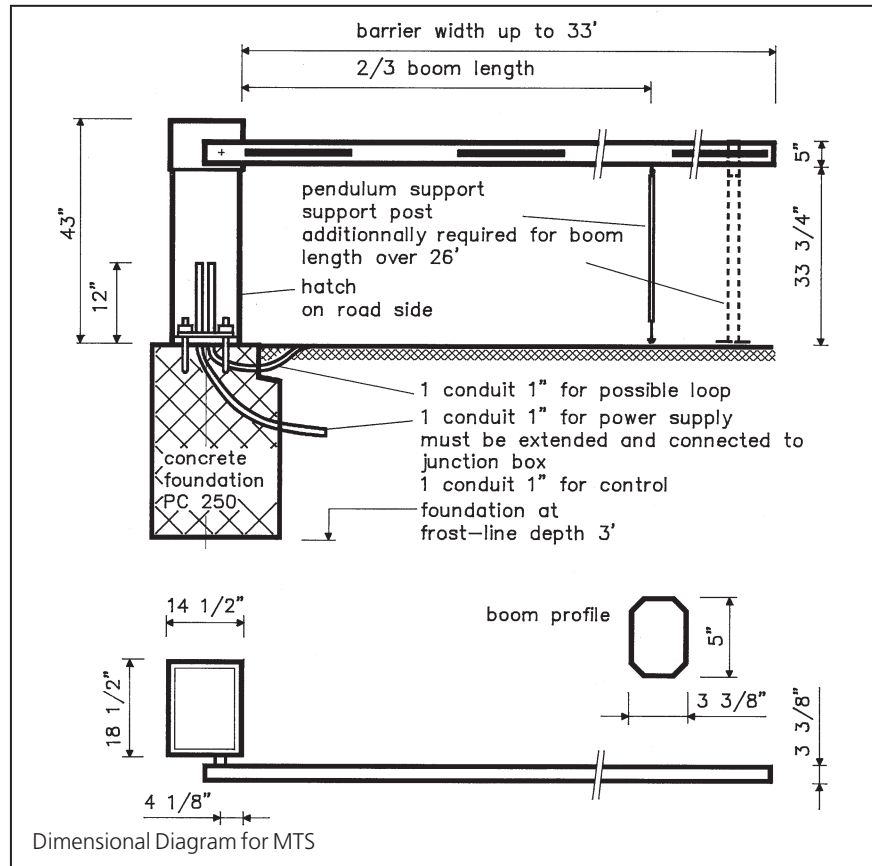

## Electrical Connection

Electrical connection for standard version MTS barriers is in accordance with the diagram overleaf.

Where our control equipment is used, special wiring diagrams are to be observed depending on the configuration. These can be obtained from the factory.

